

# Kit-Cats

## Revolutionary New Power Catamaran

*(available with optional Inflatable Sail)*

*Imagine the versatility of sailing under a mastless, fully stowable inflatable sail similar to the sails recently pioneered by youthful kite-surfing enthusiasts. No running rigging. Not even any standing rigging. Nothing to reveal your hidden sailing capabilities. Revolutionary! Visionary!*

Yes, the Power Kit-Cat™ shown in these photos is a custom vessel equipped with two powerful 225 HP 4-stroke Honda outboard engines for use when operating as a luxury power catamaran. And operated as a power catamaran, the fully commissioned vessel easily achieves a cruise speed of 28 to 30 knots, even at low power settings. [1/2 fuel (330 gallon capacity) and full water (110 gallons), and with up to 10 adults on board]. The impressive features and capabilities of this boat would keep many owners content with either the power- or trawler- cat configuration (utilizing twin 50 to 225 HP outboard engines).

But during the summer of 2003, this extraordinary vessel will pioneer a revolutionary new type of sailing. Leisure sailing with a custom-built, inflatable, steerable sail is scheduled along the beautiful east coast of Florida, utilizing an easy-to-operate inflatable sail engineered with proprietary technologies derived from modern kite-surfing and skydiving. When operated under sail alone, without power, cruise performance is anticipated in the 15 knot range.



Using components provided in the comprehensive Kit-Cat™ custom catamaran package, this vessel can be easily built even by first-time owner/builders who want to create a custom boat specially assembled to meet their own individual requirements. No special skills are needed -- anyone with the desire and motivation can achieve their dreams with the affordable Kit-Cat™ process.

With personalized touches and many fine details — your Kit-Cat™ can be everything YOU want it to be. That's the great thing about building a Kit-Cat™. Your Kit-Cat™ will be the ideal boat for you in a way that no "off-the-shelf" production boat could ever be. You will build this boat yourself, with professional hired help when you want it. You've been around boats for a long time, and you know exactly what you're looking for. You want lots of room and comfort. You want a quiet, efficient boat that will cruise fast without sacrificing comfort. If so, then a Kit-Cat™ is the perfect fit for you. It has the speed and style of a great catamaran, combined with the large deck space of an old-fashioned pontoon party boat. Whether you are cruising under power or sail, this boat enables you, your family, and your friends to enjoy every minute on the water.

### SPECIFICATIONS

<b>LOA:</b> 39' 6" <b>LWL:</b> 36' <b>Beam:</b> 19' 4" <b>Draft:</b> 24"	<b>Displacement:</b> 10,600 lbs to 15,600 lbs.
<b>Staterooms:</b> 4 (8 berths) <b>Heads:</b> 2	<b>Headroom:</b> 6' 2" (hulls)    6" 6" (main salon)
<b>Powerplants:</b> Twin 225HP Honda 4-cycle outboards	<b>Optional Sail:</b> 650 ft <sup>2</sup> inflatable/stowable kite-sail
<b>Fuel Capacity:</b> 330 gallons <b>Fresh Water:</b> 110 gallons	

800 Kemp St., Merritt Island, FL USA 32952

Internet: <http://www.kit-cats.com> Email: [info@kit-cats.com](mailto:info@kit-cats.com) Telephone: 1-321-453-7175

# Kit-Cats

## Kit-Cat™ Price List 2003

One (1) Kit-Cat™ Catamaran Hull .....	\$19,995
Hull Deck .....	4995
Trunk Cabin .....	6995
Hard Top .....	3995
Hard Top Supports .....	1495
Bulkheads (each) .....	295
Bridge Deck Package .....	5995
Performance Pads (Power Cat™ only) .....	1295
Inflatable Sail .....	<i>to be determined</i>

\*All Prices Subject to Change Without Notice. FOB Merritt Island, FL USA 32952



Fully customizable Main Salon  
...furnish to suit personal preferences.

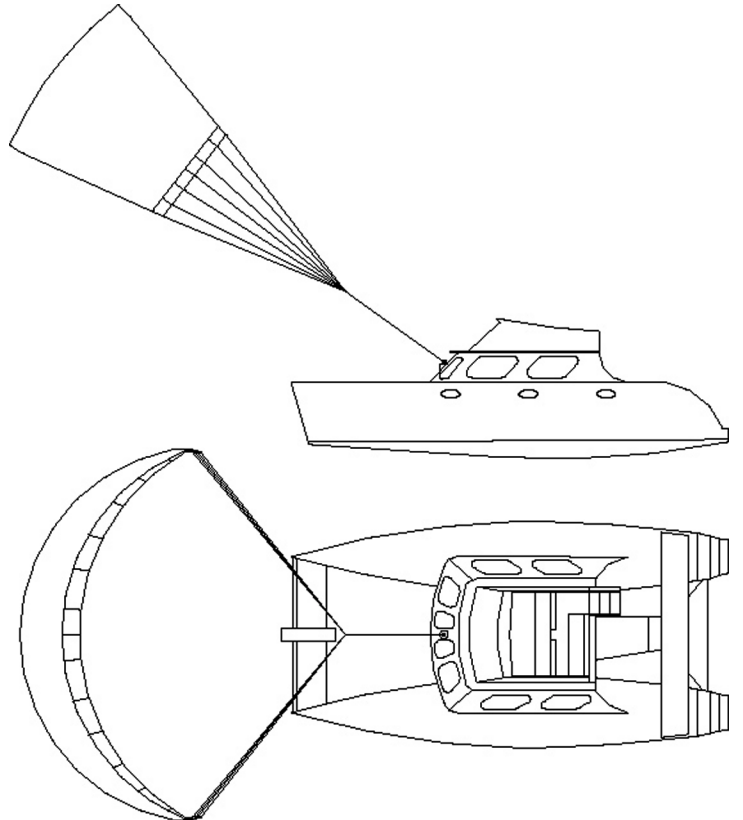

For more information or to place an order:  
Telephone 1-321-453-7175  
Web Site <http://www.kit-cats.com>